

Uniden®

XDECT 7055

OWNER'S **MANUAL**

XDECT 7055 Series User's Guide

What's in the box?

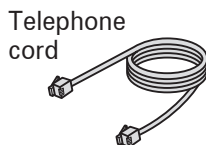
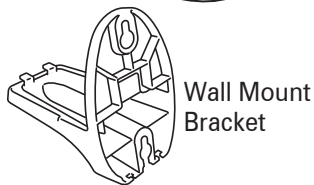
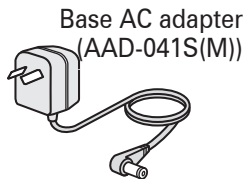

You might also find:



Charger AC adapter AAD-600S(M)



Battery cover



If you purchased model number:	You should have:
XDECT 7055	None
XDECT 7055+1	1 of each
XDECT 7055+2	2 of each
XDECT 7055+3	3 of each
XDECT 7055+4	4 of each
XDECT 7055+5	5 of each

If any items are missing or damaged, contact your place of purchase. Never use damaged products!

Need Help? Get answers at our website: www.uniden.com.au for Australian model or www.uniden.co.nz for New Zealand model.

What's in the manual?

Installing Your Phone	3	Using Privacy Mode	18
Charge the Battery	3	Using Call Transfer	19
Connect the Telephone Cord	4	Using the Intercom	19
Getting to Know Your Phone	5	Using the Answering System	20
Parts of the Base	5	Setting Up Your Answering	
Parts of the Handset	7	System	20
Reading the Displays	8	Getting Your Messages	21
Using the Menus	9	Screening Your Calls	22
Using the Base Menu	9	Using the System While You're	
Using the Handset Menus	10	Away from Home	23
Entering Text on Your Phone	11	Solving Problems	24
Using Your Phone	12	Weak or Hard To Hear Audio	25
Changing the Volume	12	Noise or Static On The Line	26
Using the Redial List	13	Resetting and Registering	
Using Caller ID and Call Waiting ..	13	Handsets	27
Using the Phonebook	14	Handling Liquid Damage	28
Chain Dialing	15	Important Information	29
Finding a Lost Handset	15	Terms Used In This Guide	29
Using Special Features	16	Specifications	29
Using Do Not Disturb	16	Battery Information	30
Using Call Block	16	Mounting the base unit on a wall	31
Using Voice Message Notification	17	One-year Limited Warranty	33
Using Multi-station Features	18		
Expanding Your Phone	18		
Using Conference Calling	18		

Important Safety Instructions!

When using your telephone equipment, basic safety precautions should always be followed to reduce the risk of fire, electric shock and injury to persons, including the following:

- **This unit is NOT waterproof.** DO NOT expose this unit to rain or moisture.
- Do not use this product near water, for example, near a bath tub, wash bowl, kitchen sink or laundry tub, in a wet basement or near a swimming pool.
- Avoid using a telephone (other than a cordless type) during an electrical storm. There may be a remote risk of electric shock from lightning.
- Do not use the telephone to report a gas leak in the vicinity of the leak.
- Use only the power cord and batteries indicated in this manual. Do not dispose of batteries in a fire. They may explode. Check with local codes for possible special disposal instructions.
- Do not place the handset in any charging cradle without the battery installed and the battery cover securely in place.

SAVE THESE INSTRUCTIONS!

Installing Your Phone

Charge the Battery

- 1) Unpack all handsets, battery packs, and battery covers. If any battery cover is already on the handset, press in on the notch and slide the cover down and off.

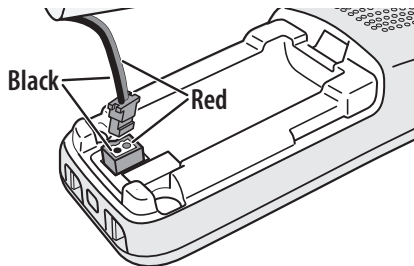
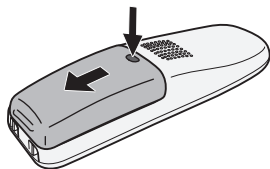

- 2) Line up the red and black wires on the battery pack with the label inside the handset.

- 3) Push the connector in until it clicks into place; tug gently on the wires to make sure the battery pack is securely connected.

- 4) Place the cover over the battery compartment and slide it up into place.
- 5) Connect the base AC adapter to the **DC IN 9V** jack on the rear of the base. Route the cord through the molded wiring channel as shown.

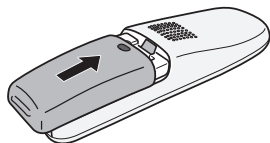

- 6) If you have accessory handsets, connect a charger AC adapter to each charger's **DC IN 9V** jack and set the plug into the notch as shown. (These adapters might already be connected.)

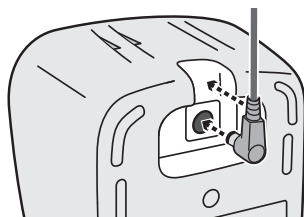
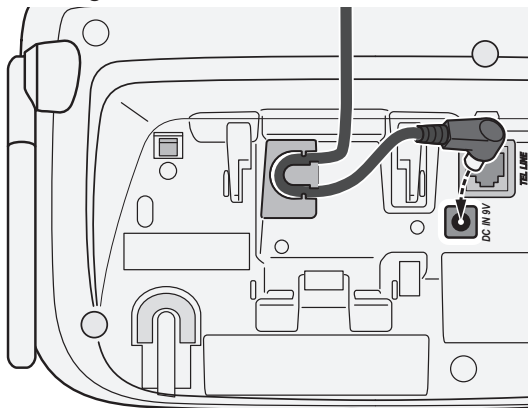

- 7) Plug the other end of each adapter into a standard 240V AC power outlet.

- 8) Place a handset in the base and any accessory handset(s) in the charger(s) with the display(s) facing forward. The **CHARGE** light on the base and each charger should all turn on.



If...	Try...
the CHARGE light does not turn on	<ul style="list-style-type: none"> - reseating the handset. - checking the AC adapter connection. - seeing if the outlet is controlled by a wall switch.

Charge all handsets completely (about 15 hours) before using them.

Connect the Telephone Cord

Use the telephone cord to connect the **TEL LINE** jack to a standard telephone wall jack.

Test the connection

- 1) Pick up the handset from the cradle and press **TALK** (T)/**FLASH**. You should hear a dial tone, and the display should say *Talk*.

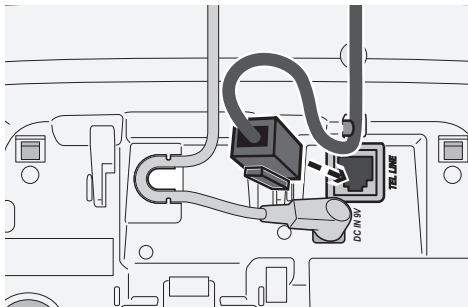

If...	Try...
you don't hear a dial tone or the display says <i>Check Tel Line</i>	checking the connection between the base and the phone jack.

- 2) Make a quick test call. (Press **END** (E)) to hang up.)

If...	Try...
there's a lot of noise or static	see page 26 for tips on avoiding interference.

- 3) Test any accessory handsets the same way. If you can't get a dial tone or the handset display says *Unavailable*, try moving the handset closer to the base or resetting it (see page 27). Charge all handsets completely (about 15 hours) before using them.

Getting to Know Your Phone





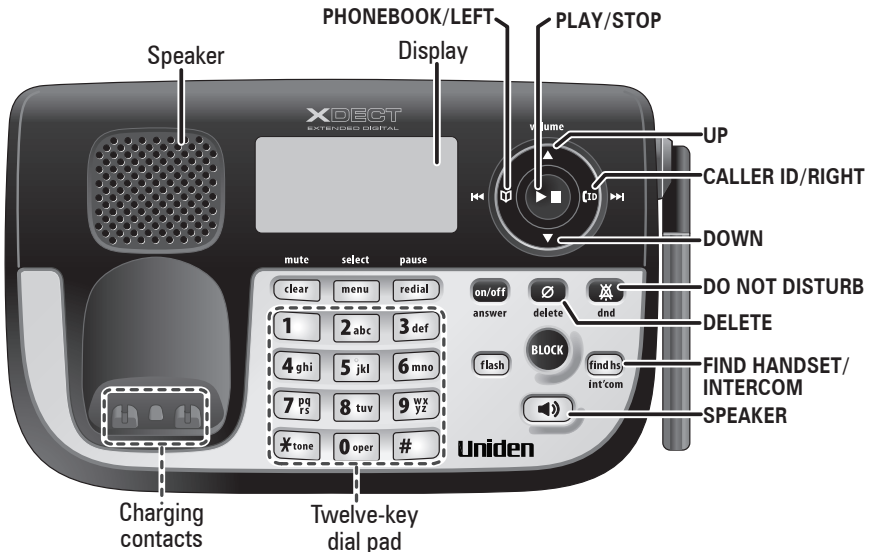

Parts of the Base

If the key name is spelled out on the key itself, it's not labeled in the drawing below.



Base keys and how they work

Key name (and icon)	What it does
CLEAR/MUTE	<ul style="list-style-type: none">- While this station is ringing: mute the ringer for this call only.- During a call: mute the microphone.- While entering text: delete one character, or press & hold to delete all the characters.
MENU/SELECT	<ul style="list-style-type: none">- In standby: open the menu.- In the menu or any list: select the highlighted item.
REDIAL/PAUSE	<ul style="list-style-type: none">- In standby: open the redial list.- While entering a phone number: insert a 2-second pause.
PLAY/STOP (▶■)	<ul style="list-style-type: none">- In standby: start playing messages.- While a message is playing: stop playing messages.- In the menu or a list: exit the menu completely.

Key name (and icon)	What it does
PHONEBOOK/ LEFT 	<ul style="list-style-type: none"> - In standby or during a call: open the phonebook. - In any menu or list: go up one level. (If you are already at the top level, the phone exits the menu and returns to the previous operation.) - During text entry: move the cursor to the left. - While playing messages: for the first 2 seconds, go to the previous message; after that: go to the start of this message.
CALLER ID/ RIGHT 	<ul style="list-style-type: none"> - In standby or during a call: open the Caller ID list. - During text entry: move the cursor to the right. - While a message is playing: skip to the next message.
UP 	<ul style="list-style-type: none"> - In standby: increase the ringer volume. - During a speakerphone call or while a message is playing: increase the speaker volume. - In the menu or any list: move the cursor up one line.
DOWN 	<ul style="list-style-type: none"> - In standby: decrease the ringer volume. - During a speakerphone call or while a message is playing: decrease the speaker volume. - In the menu or any list: move the cursor down one line.
ON/OFF	<ul style="list-style-type: none"> - In standby: turn the answering system on or off.
DELETE 	<ul style="list-style-type: none"> - While a message is playing: delete this message. - In standby: delete all messages.
DO NOT DISTURB 	<ul style="list-style-type: none"> - In standby: turn the Do Not Disturb feature on or off (see page 16).
FLASH	<ul style="list-style-type: none"> - During a call: switch to a waiting call.
BLOCK	<ul style="list-style-type: none"> - While the phone is ringing: add the incoming caller ID to the call block list (block the call).
FIND HANDSET/ INTERCOM	<ul style="list-style-type: none"> - In standby: page a handset using the intercom. - During a call: put the call on hold & start a call transfer.
SPEAKER 	<ul style="list-style-type: none"> - In standby: start a speakerphone call (get a dial tone). - During a speakerphone call: hang up.

Parts of the Handset

If the key name is spelled out on the key itself, it's not labeled in the drawing to the right.

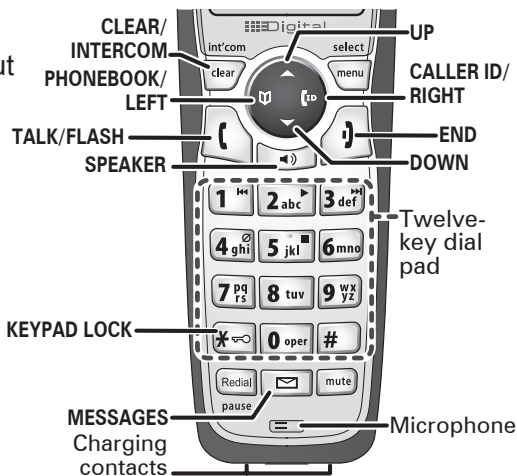

Handset keys and how they work

Key name (and icon)	What it does
UP (▲)	<ul style="list-style-type: none"> - In standby: increase the ringer volume. - During a call: increase the call volume. - In the menu or any list: move the cursor up one line.
CALLER ID/RIGHT (ID)	<ul style="list-style-type: none"> - In standby or during a call: open the Caller ID list. - During text entry: move the cursor to the right.
DOWN (▼)	<ul style="list-style-type: none"> - In standby: decrease the ringer volume. - During a call: decrease the call volume. - In the menu or any list: move the cursor down one line.
MENU/SELECT	<ul style="list-style-type: none"> - In standby: open the menu. - In the menu or any list: select the highlighted item.
END (⌵)	<ul style="list-style-type: none"> - During a call: hang up. - In the menu or any list: exit & go to standby.
CLEAR/INTERCOM	<ul style="list-style-type: none"> - In standby: page another station using the intercom. - During a call: put the call on hold & start a call transfer. - While entering text: delete one character, or press & hold to delete all the characters.
PHONEBOOK/LEFT (M)	<ul style="list-style-type: none"> - In standby or during a call: open the phonebook. - In the menu: go back to the previous screen. - During text entry: move the cursor to the left.
*/LOCK	<ul style="list-style-type: none"> - In standby: press and hold to lock or unlock the keypad.

Key name (and icon)	What it does
TALK (📞)/FLASH	- In standby: start a telephone call (get a dial tone). - During a call: switch to a waiting call.
SPEAKER (🔊)	- Switch a normal call to the speakerphone (& back).
REDIAL/PAUSE	- In standby: open the redial list. - While entering a phone number: insert a 2-second pause.
MUTE	- During a call: mute the microphone. - While the phone is ringing: mute the ringer for this call only.
MESSAGES (✉)	- In standby: access your answering system.

Reading the Displays

On the base



On the handset

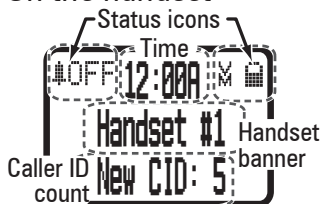

The table below shows the possible icons and what they mean. Since the icons appear based on what you're doing with the phone, you won't ever see all of these icons at the same time.

Icon	What it means
🔊 OFF	The ringer is turned off: this station will not ring when a call comes in.
M	You have a voice message waiting (see the section titled "Using Voice Message Notification" on page 17).
P	Privacy Mode is on: no other station can join your call.
🔊	The speakerphone is on.
🔇	The microphone is muted, & the caller can't hear you.
T	(Handset only) T-coil mode is on. (See "Do you use a T-coil hearing aid?" on page 26.)
🔋	(Handset only) The battery is 1) fully charged, 2) half charged, 3) getting low, or 4) empty.

Using the Menu

The menus are designed to be as easy as possible. Some users don't even need the manual once they know how to perform these actions:

Open the menu	Press MENU/SELECT .
Move the cursor	The arrow cursor on the left side of the line shows which menu item is currently highlighted. Use UP to move the cursor up & DOWN to move it down.
Select an option	Move the cursor to highlight the option, then press MENU/SELECT .
Go up one screen	Press PHONEBOOK/LEFT .
Close the menu	On the handset, press END (⏻) ; on the base, press PLAY/STOP . (If you open the menu during a call, use PHONEBOOK/LEFT to back out of the menu without hanging up.)

If you don't press any keys for thirty seconds, the phone times out and exits the menu. (When setting the day and time, the time-out period is extended to two minutes.)

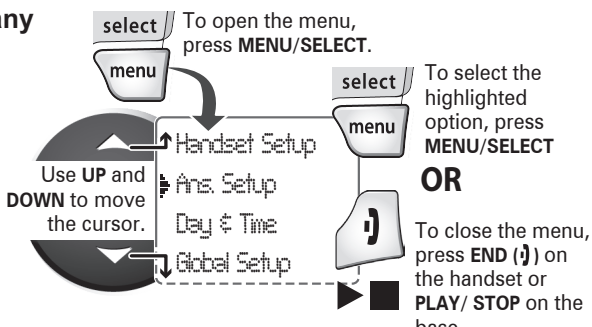

Using the Base Menu

You have the following options from the base:

<i>VMWI Reset</i>	Reset the voice message waiting indicator to bring it back into sync with your voice mail service (see page 17).
<i>Call Blocking</i>	Block unwanted calls from up to 20 phone numbers and manage your call block list (see page 16).
<i>Register Handset</i>	Register additional handsets to the base or re-register a handset that you had to reset for some reason (see "Resetting and Registering Handsets" on page 27).

Using the Handset Menus

Handset Setup

You can change these settings separately for each handset.

<i>T-coil</i>	Turn on T-coil mode to reduce noise on some hearing aids (see "Do you use a T-coil hearing aid?" on page 26).
<i>Ringer Tones</i>	Choose one of four melodies or four tones for the handset's main ring tone. As you highlight each ring tone, the phone plays a sample of the tone. When you hear the tone you want, press MENU/SELECT .
<i>Personal Ring</i>	Turn on the personal ring feature. If you have Caller ID, this feature lets you assign special ring tones to anyone in your phonebook: this handset will use the special ring tone when that person calls.
<i>Autotalk</i>	Turn on Auto Talk so you can answer the phone just by picking up the handset from the cradle (without having to press any buttons).
<i>Any Key Answer</i>	Turn on Any Key Answer so you can answer the phone by pressing a key on the twelve-key dial pad.
<i>Banner</i>	Change the name used on the handset's display.
<i>Key Touch Tone</i>	Have the keypad sound a tone when you press a key.

Ans. Setup

This menu controls the options and settings for your answering system (see "Ans. Setup menu options" on page 20).

Day & Time

You need to set the day & time so messages get the right time stamp.

- 1) Use **UP & DOWN** to choose the day of the week; press **MENU/SELECT**.
- 2) Use the number keypad to enter the hour and minutes.
- 3) Use **UP & DOWN** to select *AM* or *PM*; press **MENU/SELECT**.

Global Setup

The settings on this menu apply to all handsets and the base. Before changing these settings, make sure the phone is in standby and all handsets are within range of the base. (Only one handset at a time can change these settings.)

<i>Set Line Mode</i>	Do not change this setting unless instructed to by customer service.
<i>Insert 0</i>	This feature adds "0" or "00" at the beginning of the number received from Caller ID. The default setting for New Zealand is ON. The default setting for Australia is OFF.

Call Blocking

This menu lets you block unwanted calls from up to 20 phone numbers and manage your call block list (see page 16).

Entering Text on Your Phone

When you want to enter text into your phone (for example, a name in the phonebook), use the twelve-key dial pad to enter the letters printed on the number keys. Here's how it works:

- ◆ The phone enters the letters in the order they appear on the key. For example, if you press the number key **2** once, the phone enters the letter **A**. Press **2** twice for **B**, and three times for **C**.
- ◆ If you press the key again after the last letter, the phone starts the same letter sequence with small letters. If you press **2** four times in a row, the phone enters **a** (small letter). Press **2** five times for **b**, and six times for **c**.
- ◆ If you see the icon **[Aa]** in the display, the phone enters capital letters first (**A B C**), then small letters (**a b c**), then the number on the key (**2**). The icon **[aA]** means the phone starts at the small letters, so it enters small letters first, then the number on the key, then capital letters.
- ◆ The phone automatically uses a capital letter for the first letter and any letter right after a space; all other times, it uses small letters.
- ◆ If two letters in a row use the same number key, enter the first letter, then use **CALLER ID/RIGHT** to move the cursor to the next position to enter the second letter.

To	Follow these steps
Switch between capital & small letters	Press * .
Move the cursor	Press PHONEBOOK/LEFT to move the cursor to the left or CALLER ID/RIGHT to move the cursor to the right.
Leave a blank space	Press # .
Erase one letter	Move the cursor to the letter you want to erase and press CLEAR (CLEAR/INTERCOM on the handset; CLEAR/MUTE on the base).
Erase the entire entry	Press & hold CLEAR .
Enter punctuation or a symbol	Press 0 to rotate through the available symbols.

Using Your Phone

To...	From a handset	From a handset speakerphone	From the base speakerphone
make a call: Dial the number, then	Press TALK (📞)/ FLASH .	Press SPEAKER .	Press SPEAKER .
answer a call	Press TALK (📞)/ FLASH .	Press SPEAKER .	Press SPEAKER .
hang up	Press END (📞) or put the handset in the cradle.		Press SPEAKER .
switch between the speaker & earpiece	Press SPEAKER .	Press SPEAKER .	NA
mute the microphone during a call	Press MESSAGES . Press again to turn the microphone back on.		Press CLEAR/MUTE .
put a call on hold	Press CLEAR/INTERCOM . If the call is on hold for 5 minutes, it will be disconnected.		Press FIND HANDSET/INTERCOM .
return to a call on hold	Press TALK (📞)/ FLASH .	Press SPEAKER .	Press SPEAKER .
mute the ringer for this call only	While the phone is ringing, press MESSAGES .		While the phone is ringing, press CLEAR/MUTE .

Changing the Volume

You can set the volume of the ringer and speaker separately for the base and each handset; you can also set the earpiece volume on each handset. For each item, press **UP** to make it louder or **DOWN** to make it softer. The available volume levels and how change them are listed below:

Change the	When	On the base	On a handset
ringer volume	the phone is in standby	select <i>Off</i> , <i>Low</i> , <i>Medium</i> , or <i>High</i>	select <i>Off</i> , <i>Low</i> , <i>Medium</i> , or <i>High</i>
earpiece volume	you are on a normal call	NA	choose one of 6 volume levels
speaker volume	you use the speakerphone for a call or getting messages	choose one of 10 volume levels	choose one of 6 volume levels

Using the Redial List

The phone saves the last 5 numbers you dial on each station. To open the redial list, press **REDIAL/PAUSE**; use **UP** and **DOWN** to scroll through the list. To close the list, press **PHONEBOOK/LEFT**. With the phone in standby, open the list and find the number you want. Then:

to redial the selected number	On the handset, press TALK (📞)/ FLASH or SPEAKER ; on the base, press SPEAKER .
to delete the number	Press MENU/SELECT & select <i>Delete Entry</i> .
to save it to the phonebook	Press MENU/SELECT & select <i>Store Into Pb</i> .

Using Caller ID and Call Waiting

You have to subscribe to Caller ID, Call Waiting, and Caller ID on Call Waiting services to use the features described in this section: contact your telephone provider for more information.

When a call comes in, the phone displays the caller's number and name (if available). The phone saves the information for the last 30 received calls to the *CID list*. When it's in standby, the phone displays how many calls came in since the last time you checked the CID list.

Open the CID list	Press CALLER ID/RIGHT .
Scroll through the CID list	Press DOWN to scroll through the list from newest to oldest. Press UP to scroll from oldest to newest.
Close the CID list	Press PHONEBOOK/LEFT .

Dialing from the Caller ID list

- 1) Find the entry you want to dial.
 - 2) On the handset, press **TALK** (📞)/**FLASH** or **SPEAKER** to dial the number; on the base, press **SPEAKER**.
- (You can also press **TALK** (📞)/**FLASH** or **SPEAKER** before you open the CID list. Find the number you want to dial, then press **MENU/SELECT**.)

Caller ID menu options

Open the CID list with the phone in standby. Find the number you want and press **MENU/SELECT**. Choose one of these CID menu options:

<i>Delete Entry</i>	Erase this Caller ID number.
<i>Store Into Pb</i>	Add this number to this station's phonebook. The phone prompts you to enter a name & edit the number; handsets also prompt you to choose a personal ring.
<i>Delete All</i>	Erase this station's CID list. (This does not affect the CID lists saved on any other stations.)
<i>Add Call Block</i>	(Handset only) Add the number to the call block list (see page 16). To add the number to the call block list from the base, press BLOCK instead of entering the menu.

Using Call Waiting

If you get a Call Waiting call, the phone sounds a tone and displays any CID information received for the waiting call.

For Australian Model:

Press **TALK (📞)/FLASH** on the handset (or **FLASH** on the base) and then press 2 to accept the waiting call. The first caller is put on hold, and you will hear the new caller after a short pause. To return to the original caller, press **TALK (📞)/FLASH (FLASH on the base)** and then 2 again.

For New Zealand Model:

Press **TALK (📞)/FLASH** on the handset (or **FLASH** on the base) to accept the waiting call. The first caller is put on hold, and you will hear the new caller after a short pause. To return to the original caller, press **TALK (📞)/FLASH (FLASH on the base)** again.

Using the Phonebook

Each station can store up to 70 entries in its phonebook.

Open/close the phonebook	Press PHONEBOOK .
Scroll through the entries	Press DOWN to scroll through the phonebook from A to Z or UP to scroll from Z to A.
Jump to entries that start with a certain letter	Press the number key corresponding to the letter you want to jump to.
Dial an entry	<ol style="list-style-type: none">1. Find the entry you want to dial.2. On the handset, press TALK (📞)/FLASH or SPEAKER; on the base, press SPEAKER.

Phonebook menu options

Open the phonebook with the phone in standby, then press **MENU/SELECT** to open the phonebook menu. Choose one of these options:

<i>Create New</i>	Add an entry to your phonebook. The phone prompts you to enter the name & phone number. (Handsets will also prompt you to choose a personal ring.)
<i>Copy All</i>	Copy the whole phonebook to another station.
<i>Delete All</i>	Erase all the entries in this station's phonebook. (This does not affect the entries saved on any other stations.)

Phonebook entry options

With the phone in standby, open the phonebook and find the entry you want. Press **MENU/SELECT** to open the individual phonebook entry menu. Choose one of these options:

<i>Edit</i>	Edit this entry. The phone prompts you to enter the name & phone number. (Handsets will also prompt you to choose a personal ring.)
<i>Copy</i>	Copy this entry to another station.
<i>Delete</i>	Erase this entry.

Chain Dialing

- ◆ If you often have to enter a series of digits or a code number during a call, you can save that code number to a phonebook entry and use the phonebook to send the code number.
- ◆ Enter the code number (up to 20 digits) into the phonebook just like a regular phonebook entry. Be sure to enter the code number into the phonebook exactly as you would enter it during a call.
- ◆ When you hear the prompt that tells you to enter the number, open the phonebook and find the entry that contains your code number. Press **MENU/SELECT** to transmit the code. Or, if you change your mind, use **PHONEBOOK/LEFT** to close the phonebook.

Finding a Lost Handset

With the phone in standby, press **FIND HANDSET/INTERCOM** on the base. Select the handset you want to find (or *All* to page all handsets). The paged handset(s) beep for 1 minute or until you press **FIND HANDSET/INTERCOM** again or press **TALK (T)/FLASH** followed by **END (E)** on the handset.

Using Special Features

Using Do Not Disturb

- ◆ The *Do Not Disturb* or *DND* feature turns off the ringers of the base and all handsets at the same time.
- ◆ With the phone in standby, press and hold **DO NOT DISTURB** on the base. The phone automatically turns on the answering system and shows *Do Not Disturb* in the display on all stations.
- ◆ To cancel, press **DO NOT DISTURB** again.

If you turn the answering system off while DND is on, the phone turns off DND along with the answering system.

Using Call Block

If you subscribe to Caller ID, you can save phone numbers to the call block list. When a call comes in, the phone compares the received phone number to the numbers on the call block list. If the phone number is on the list, the phone replaces the caller's name with *Call Blocked* and disconnects the call. (The caller hears a reject guidance.)

The call block list holds 20 entries, and all stations share the same list. You can add entries through the *Call Blocking* menu, from the CID list, or by blocking incoming calls. (Only one station can edit the call block list at a time.)

Blocking incoming calls (Base only)

When the phone rings, wait until the display shows the Caller ID information (usually after the second ring). If you want to block the call and add this number to the call block list, press **BLOCK** on the base. When the phone asks you to confirm, press **MENU/SELECT** or **BLOCK**.

Blocking an incoming call from an "Unknown" or "Private" number is the same as selecting *Unknown Number* or *Private Number* from the *Call Blocking* menu.

Call Blocking menu options

With the phone in standby, open the menu and select *Call Blocking*. Choose one of these options:

<i>View Number</i>	See the numbers on your call block list.
<i>Create New</i>	(Handset only) Add an entry to your call block list. The phone will prompt you to enter a name & phone number.

<i>Private Number</i>	(Handset only) Block all calls from numbers reported by CID as "Private." (This does not count as one of the 20 entries.)
<i>Unknown Number</i>	(Handset only) Block all calls from numbers reported by CID as "Unknown". (This does not count as one of the 20 entries.)

Call block entry options

With the phone in standby, open the call block list and find the entry you want. Press **MENU/SELECT** to open the individual entry menu.

Choose one of these options:

<i>Edit</i>	(Handset only) Edit this entry. The phone will prompt you to edit the name & phone number.
<i>Delete</i>	Erase this entry from the list & allow calls from this number.

Using Voice Message Notification

This feature supports Frequency-Shift Keying (FSK) message notification. Contact your voice mail provider for more details.

If you subscribe to a voice mail service, your phone can notify you when you have a new message waiting. When you have new messages, the voice message icon (📞) appears in the display, and the new message light (at the top of the handset) blinks.



Resetting the voice message indicator

If the voice message icon remains after you check your messages, you can reset it. Open the menu on the base and select *VMWI Reset*. Select **Yes** to reset the indicator.

Using Multi-station Features

The expandable base and the cordless handset give you some useful multi-station features. (A station can be any handset or the base.)

Expanding Your Phone

- ◆ Your base supports a total of six cordless handsets: the one that came with the base and up to five XDECT 7005 accessory handsets.
- ◆ Your base might be compatible with other Uniden accessory handsets: please visit our website for a list of compatible handsets.
- ◆ Accessory handsets must be registered to the base before you can use them. Handsets that aren't registered display a *Handset not registered* message. For instructions on registering handsets to this base, see page 27 or the manual for the accessory handset.
- ◆ Any accessory handsets that came packaged with the base are already registered to that base for you.
- ◆ If a handset was previously registered to a base, you have to reset it so you can register it to a new base (see page 27 for XDECT 7005).

Using Conference Calling

When an outside call comes in, the base and two handsets can join in a conference call with the outside caller. To join the call, just press **SPEAKER** on the base or **TALK** (TALK/FLASH) on a handset. To leave the conference call, hang up normally; the other station remains connected to the call. (You can also use the handset speakerphone for a conference call, just like you can with a normal call.)

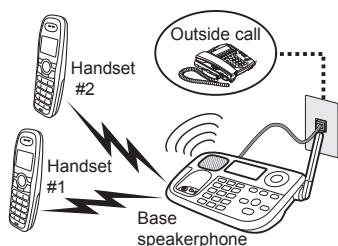

Using Privacy Mode

You can prevent other stations from joining a call. Start your call as usual, then press **MENU/SELECT**: the display shows *Call Privacy*. Press **MENU/SELECT** again to turn privacy mode on (you'll see a  in the display). When you hang up, privacy mode turns off automatically. As long as you have privacy mode on, no other stations can interrupt your call. To allow another station to join the call, just turn privacy mode off by repeating the process above (press **MENU/SELECT** twice).

Using Call Transfer

To...	From the base	From a handset
transfer a call	<ol style="list-style-type: none"> 1. Press FIND HANDSET/INTERCOM to put the call on hold. 2. Select the station you want to transfer the call to, or select A// to page all the stations at the same time. <p>When the other station accepts the call, you'll be disconnected, but you can join the call again.</p>	<ol style="list-style-type: none"> 1. Press CLEAR/INTERCOM to put the call on hold.
cancel a transfer	Press SPEAKER to return to the call.	Press TALK (📞)/FLASH to return to the call.
accept a transferred call	<ol style="list-style-type: none"> 1. To answer the page & speak to the transferring station, press FIND HANDSET/INTERCOM. 2. To accept the call, press SPEAKER. 	<ol style="list-style-type: none"> 1. Press CLEAR/INTERCOM. press TALK (📞)/FLASH.

Using the Intercom

Here are some things you need to know about using the intercom:

- ◆ Whenever the phone is in standby, you can make an intercom call between stations without using the phone line.
- ◆ You can make an intercom call from any station, but only two stations can be in an intercom call at any time.
- ◆ If an outside call comes in during an intercom call, the phone shows the CID information. If the other station hasn't answered the page, the phone cancels the page so you can answer the incoming call.

To...	From the base	From a handset
make an intercom page	<ol style="list-style-type: none"> 1. Press FIND HANDSET/INTERCOM. 2. Select the station you want to talk with, or select A// to page all the stations at the same time. 	1. Press CLEAR/INTERCOM .
cancel a page	Press FIND HANDSET/INTERCOM .	Press END (📞) .
answer an intercom page	Press FIND HANDSET/INTERCOM or SPEAKER .	Press CLEAR/INTERCOM or TALK (📞)/FLASH .
leave an intercom call	Press FIND HANDSET/INTERCOM .	Press END (📞) .
answer an outside call during an incoming call	Press SPEAKER .	Press TALK (📞)/FLASH

Using the Answering System

Setting Up Your Answering System

You can set up your answering system from any handset.

To...	Follow these steps
Record your personal outgoing message or greeting	<p>Your greeting can be between 2 seconds and 30 seconds long. If you don't record an outgoing message, the system uses a pre-recorded greeting: <i>Hello, no one is available to take your call. Please leave a message after the tone.</i></p> <ol style="list-style-type: none">1. Press MESSAGES to access the answering system. Wait until the system finishes its announcements, or press 5 (STOP) to skip them.2. Press 8.3. Wait for the system to say "Record greeting," then begin speaking.4. When you're finished, press 8 to stop recording. The system plays back your new greeting.5. To keep this greeting, press END (⏏). To re-record it, go back to step 2.
Switch between the pre-recorded greeting & your own greeting	<ol style="list-style-type: none">1. Press MESSAGES to access the answering system. Wait until the system finishes its announcements, or press 5 (STOP) to skip them.2. Press 6. The system plays back the greeting it is currently using.3. Press 6 again to switch greetings.
Delete your greeting	<ol style="list-style-type: none">1. Switch to your personal greeting following the steps above.2. While the system is playing back your greeting, press 4.

Ans. Setup menu options

You can change the answering system options from any handset. Just open the menu and select *Ans. Setup*.

<i>Security Code</i>	Enter a 2-digit PIN so you can access your answering system from any touch-tone phone (see page 23).
<i>Ring Time</i>	Set the number of rings (6, 9 or 12) before the answering system answers the phone. Choose <i>Toll Saver (TS)</i> to have the system pick up after 2 rings if you have new messages or after 4 rings if you don't.

<i>Record Time</i>	Set the amount of time callers have to leave a message, either 1 minute or 4 minutes. Choose <i>Announce Only</i> if you don't want the system to let callers to leave a message.
<i>Message Alert</i>	Have the system beep every 15 seconds when you have a new message; the beeping stops when you listen to all your new messages. (To mute the alert without listening to your messages, press any key on the base.)
<i>Call Screen</i>	Turn on the call screen feature so you can hear callers as they leave messages on the base speaker (see page 22).
<i>Ans. On/off</i>	Turn your answering system on or off. (To turn your system on or off from the base, just press ON/OFF .)

Getting Your Messages

Accessing your answering system from a handset

You can access your system from a handset whenever the phone is in standby.

Press **MESSAGES/MUTE** to start remote operation mode.

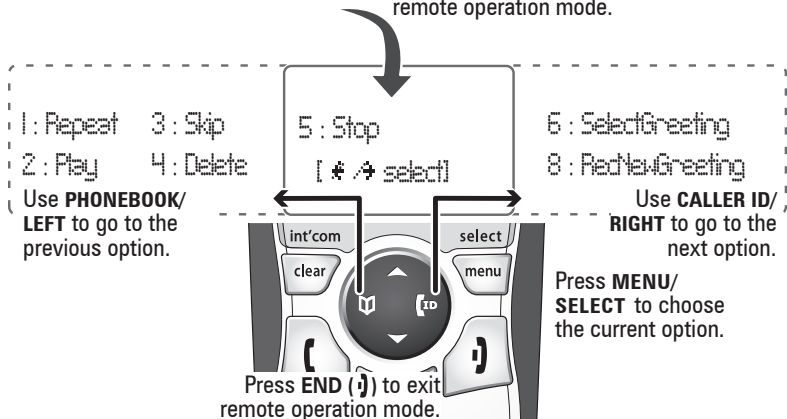

- ◆ During remote operation, the phone beeps to let you know it's waiting for your next command.
- ◆ You can press the number key next to the commands instead of scrolling through them.
- ◆ If you don't press any keys for 30 seconds, the phone returns to standby.
- ◆ Only one handset can access the system at a time.

How to operate your answering system

To...	From the base	From a handset (remote operation)
play new messages	Press PLAY/STOP . The system announces the number of new & old messages, then plays the first new message followed by the day & time it was received. Then the system plays the new messages in the order they were received.	Press MESSAGES .
restart the current message	Press PHONEBOOK/LEFT .	Press 1 or select 1:Repeat .
replay previous messages	Press PHONEBOOK/LEFT repeatedly until you hear the message you want to replay.	Press 1 or select 1:Repeat repeatedly until you hear the message you want to replay.
skip a message	Press CALLER ID/RIGHT .	Press 3 or select 3:Skip .
delete a message	While the message is playing, press DELETE .	While the message is playing, press 4 or select 4:Delete .
delete all of your messages	With the phone in standby, press DELETE . When the system asks you to confirm, press DELETE again.	Not available.
play old messages	After the system plays the new messages, press PLAY/STOP again.	press 2 or select 2:Play .
end the operation	Press PLAY/STOP .	Press END (⏻) .

Screening Your Calls

Another feature your answering system gives you is *call screening*. While the system is taking a message, you can hear the caller on the base speaker (if you turn on *Call Screen*) or from a handset.

To...	From the base	From a handset
hear the caller leaving a message	Just listen to the caller over the speaker.	Press MESSAGES .
answer the call	Press SPEAKER .	Press TALK (📞)/FLASH .
mute the call screen without answering	Press CLEAR/MUTE .	Press END (⏻) or return the handset to the cradle.

- ◆ If you mute the call screen, the system continues taking the message: it just stops playing through the speaker.

- ◆ Only one handset at a time can screen calls. If another handset is screening the call, the handset beeps and returns to standby.

Using the System While You're Away from Home

You can also operate your answering system from any touch-tone phone. Before you can use this feature, you have to program a security code.

Programming a security code

- 1) With the phone in standby, open the menu from any handset.
- 2) Select *Ans. Setup*, then select *Security Code*.
- 3) Use the number keypad to enter a two-digit security code (00 to 99). Press MENU/SELECT when you're finished.

Remember to make a note of your new security code!

Dialing in to your system

- 1) Call your telephone number and wait for the system to answer. (If your answering system is off, it will answer after about fifteen rings and sound a series of beeps instead of your greeting.)
- 2) During the greeting (or beeps), press # and **immediately** enter your security code. (You have 3 tries to enter you security code: if you enter it wrong 3 times, the system hangs up and returns to standby.)
- 3) The system announces the current time, the number of messages stored in memory, and a help prompt. Then it starts beeping intermittently to let you know it's waiting for your command.
- 4) When you hear the intermittent beeping, enter a command from the chart to the right.

If you don't press any keys for 15 seconds, the phone will hang up and return to standby.

#-1	Repeat message
#-2	Play message
#-3	Skip message
#-4	Delete message
#-5	Stop playback
#-6	Turn the system on
#-9	Turn the system off
#-0	Hear help prompts

Solving Problems

If you have any trouble with your phone, try these simple steps first. If you still have a question, visit the website listed on the front cover.

If...	Try...
No stations can make or receive calls.	<ul style="list-style-type: none">- Checking the telephone cord connection.- Disconnecting the base AC adapter. Wait a few minutes, then reconnect it.
One handset can't make or receive calls.	<ul style="list-style-type: none">- Moving the handset closer to the base.- Resetting the handset.
A station can make calls, but it won't ring.	<ul style="list-style-type: none">- Making sure the ringer is turned on.- Making sure Do Not Disturb is turned off.
A handset's display won't turn on.	<ul style="list-style-type: none">- Charging the battery for 15-20 hours.- Checking the battery pack connection.
A handset is not working.	<ul style="list-style-type: none">- Charging the battery for 15-20 hours.- Checking the battery pack connection.- Resetting the handset.
A handset says <i>Unavailable</i> .	<ul style="list-style-type: none">- Moving the handset closer to the base.- Seeing if another station has Privacy Mode on.- Making sure the base is plugged in.
No stations will display any Caller ID information.	<ul style="list-style-type: none">- Letting calls ring at least twice before answering.- Seeing if the call was placed through a switchboard.- Checking with your telephone service provider to make sure your Caller ID service is active.
Caller ID displays briefly & then clears.	<ul style="list-style-type: none">- You may have to change the line mode. Visit the website for more information.
I can't transfer calls.	<ul style="list-style-type: none">- Resetting all the handsets.
I can't get two handsets to talk to the caller.	<ul style="list-style-type: none">- Making sure both handsets are registered to this base.- Making sure no station is in Privacy Mode.
The phone keeps ringing if I answer on an extension.	<ul style="list-style-type: none">- You may have to change the line mode. Visit the website for more information.
The answering system does not work.	<ul style="list-style-type: none">- Making sure the answering system is turned on.- Making sure the base AC adapter is plugged into a continuous wall outlet (i.e., not controlled by a wall switch).

If...	Try...
The answering system won't record messages.	- Making sure the <i>Record Time</i> is not set to <i>Announce Only</i> . - Deleting messages (the memory may be full).
A handset can't access the answering system.	- Making sure no other handset is using the system. - Making sure the phone is in standby.
My outgoing message is gone.	- Seeing if there was a power failure. You may have to re-record your personal outgoing message.
I can't hear the base speaker.	- Making sure call screening is turned on. - Changing the base speaker volume.
Messages are incomplete.	- The incoming messages may be too long. Remind callers to leave a brief message. - Deleting messages (the memory may be full).
The system keeps recording if I answer on an extension.	- You may have to change the line mode. Visit the website for more information.
I can't register a handset.	- Seeing if you already have 6 handsets registered to this base. - Resetting the handset.

Weak or Hard To Hear Audio

If a caller's voice sounds weak or soft, the signal might be blocked by large metal objects or walls; you might also be too far from the base, or the handset's battery may be weak.

- ◆ Try moving around while you're on a call or moving closer to the base to see if the sound gets louder.
- ◆ Make sure the handset's battery is fully charged.
- ◆ Try adjusting the earpiece volume or the audio tone (see below).

Adjust the audio tone

During a call, open the menu and select *Audio Tone*. Choose one of the three audio tone options: *High Tone*, *Natural Tone* (recommended for hearing aid users), or *Low Tone*. You may have to experiment to figure out which audio tone works best for you.

Noise or Static On The Line

Interference is the most common cause of noise or static on a cordless phone. Here are some common sources of interference:

- ◆ electrical appliances, especially microwave ovens
- ◆ computer equipment, especially wireless LAN equipment and DSL modems
- ◆ radio-based wireless devices, such as room monitors, wireless controllers, or wireless headphones or speakers
- ◆ large florescent light fixtures (especially if they give off a buzzing noise)
- ◆ other services that use your phone line, like alarm systems, intercom systems, or broadband Internet service

Here are some hints for when the static is...

on 1 handset or in 1 location:	on all handsets or in all locations:
<ul style="list-style-type: none">- Check nearby for one of the common interference sources.- Try moving the handset away from a suspected source, or try moving the suspected source so it's not between the handset & the base.- Try moving closer to the base. There is always more noise at the edges of the base's range. If the handset displays an <i>Out of Range</i> message, you need to move closer to the base.	<ul style="list-style-type: none">- Check near the base for the source of interference.- Try moving the base away from a suspected source, or turn off the source if possible.- If the base has an adjustable antenna, try raising the antenna so it stands straight up.- If you have any service that uses the phone line, you might need a filter (see below).

Installing a line filter or DSL filter

Sometimes, broadband Internet services that use the telephone line can interfere with phones. One of these services-DSL-often causes static on telephones. A DSL filter or telephone line filter usually solves

Do you use a T-Coil hearing aid?

If you have a hearing aid equipped with a telecoil (T-coil) feature, the interaction between the hearing aid & digital cordless phones can cause noise in the handset. If you have a T-coil hearing aid & you have problems with noise on the line, try turning on *T-coil* mode. Open the menu. Select *Handset Setup*, then select *T-coil*.

Using T-coil mode can shorten the handset's talk time; make sure to watch the battery status and keep the battery charged.

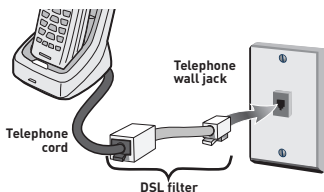

this problem. The technician who installed your DSL service might have left some filters for you; if not, call your DSL provider or look in any electronics store.

Plug the DSL filter into the telephone wall jack and plug your phone's base into the filter. Make a test call to make sure the noise is gone.

Resetting and Registering Handsets

If you are having trouble with a handset or if you want to replace one, you need to clear the registration information from the base and the handset:

Do you have the base the handset is registered to?	
Yes	No
<ol style="list-style-type: none"> 1. Press & hold END (⏹) and # until the <i>System Reset</i> menu appears (about 5 seconds). 2. Select <i>Deregister HS</i>. The display lists all registered handsets. 3. Select the handset you want to reset. 4. When the phone asks you to confirm, select <i>Yes</i>. The handset clears its information from the base & deletes its own link to the base. 	<ol style="list-style-type: none"> 1. Press & hold END and # until the <i>System Reset</i> menu appears (about 5 seconds). 2. Select <i>Base Unavailable</i>. 3. When the phone asks you to confirm, select <i>Yes</i>. The handset deletes its own link without contacting the base.

When you reset a handset (or if you buy a new one), that handset displays a *Handset Not Registered* message. If you see this message on a handset, you need to register it to a base before you can use it.

Registering a handset

Does the handset fit in the base cradle?	
Yes	No
Place the handset in the base. The display should say <i>Handset Registering</i> .	<ol style="list-style-type: none"> 1. On the base, open the menu and select <i>Register Handset</i>. The display should say <i>Handset Registering</i>. 2. On the handset you want to register, press and hold # until the handset display says <i>Handset Registering</i> (about 2 seconds).

In about 30 seconds, the handset display should say *Registration Complete*. Press **TALK** (☎)/**FLASH** and make sure you get a dial tone.

If...	Try...
- you don't hear a dial tone - the display says <i>Registration Failed</i>	Making sure the handset is fully charged, then start over at step 1.

To register a handset to a different base, see the section "Expanding Your Phone" in the user's guide for the other base.

Handling Liquid Damage

Moisture and liquid can damage your cordless phone.

- ◆ If the handset or base is exposed to moisture or liquid, but only the exterior plastic housing is affected, wipe off the liquid, and use as normal.
- ◆ If moisture or liquid has entered the plastic housing (i.e. liquid can be heard in the phone or liquid has entered the handset battery compartment or vent openings on the base), follow these steps:

Handset	Base
<ol style="list-style-type: none"> 1. Remove the battery cover & disconnect the battery. 2. Let dry for at least 3 days with the battery disconnected and the cover off for ventilation. 3. After the handset dries, reconnect the battery pack and replace the cover. Recharge the battery fully (15-20 hours) before using. 	<ol style="list-style-type: none"> 1. Disconnect the AC adapter to cut off the power. 2. Disconnect the telephone cord. 3. Let dry for at least 3 days before reconnecting.

IMPORTANT: You must unplug the telephone line while recharging the battery pack to avoid charge interruption.

CAUTION! DO NOT use a microwave oven to speed up the drying process. This will cause permanent damage to the handset, base and the microwave oven.

Important Information

Terms Used In This Guide

Accessory handset	An extra handset that can register to and be used with an expandable phone base. All accessory handsets must be registered to a base before you can use them.
Base	The main part of the phone. It connects to your phone line and lets you make and receive calls. Most bases also have a cradle to store a handset.
CIDCW	(CID on Call Waiting.) A service that shows CID for calls that come in during another call.
Call Waiting	A service that lets you receive calls while you are on another call.
Caller ID	(Also called CID.) A service that shows the name and number of incoming callers.
Charger	A cradle that stores and charges a handset but doesn't connect to the phone line.
Cradle	The part of the phone that stores a handset. While in a cradle, a handset is always in standby, and any keys are locked.
During a call	The station is currently on a call or has activated a dial tone.
Handset	A cordless handset that you use to dial the phone and talk to callers.
In standby	The phone is inactive: there is no dial tone, no station is on a call or listening to messages.
Station	Any handset or the base.

Specifications

		Base	Charger
AC adapter	Part number	AAD-041S(M)	AAD-600S(M)
	Input voltage	240V AC, 50Hz	240V AC, 50Hz
	Output voltage	9V DC@ 350mA	9V DC@ 210mA
Battery pack	Part number	BT-694 or BT-694s	
	Capacity	650mAh (BT-694) or 500mAh(BT-694s)	

- ♦ Use only the supplied AC adapters.
- ♦ Be sure to use the proper adapter for the base & any chargers.
- ♦ Do not place the power cord where it creates a trip hazard or where it could become chafed & create a fire or electrical hazard.

- ♦ Do not place the base in direct sunlight or subject it to high temperatures.

Battery Information

- Fully charged, the battery should provide about 10 hours of talk time and about 7 days of standby time. For best results, return the handset to the cradle after each call to keep it fully charged.
- Keep an eye on the battery status icon. When the battery gets too low, the handset shows a low battery alert. If you hear a strange beep during a call, check the display: if you see the low battery alert, finish your conversation as quickly as possible and return the handset to the cradle. If the handset is in standby, none of the keys will operate.
- With normal use, the battery should last about one year. Replace the battery when the talk time becomes short even when the battery is charged. To buy a replacement battery, visit the website listed on the front cover.

Rechargeable Nickel-Metal-Hydride Battery Warning

CAUTION! Risk of explosion if battery is replaced by an incorrect type! Dispose of used batteries according to the instructions. Do not open or mutilate the battery. Disconnect the battery before shipping this product.

- This equipment contains a rechargeable Nickel-Metal-Hydride battery.
- The rechargeable batteries contained in this equipment may explode if disposed of in a fire.
- Do not short-circuit the battery.
- Do not charge the rechargeable battery pack used in this equipment with in any charger other than the one designed to charge this battery pack as specified in the owner's manual. Using another charger may damage the battery pack or cause the battery pack to explode.

Uniden works to reduce lead content in PVC coated cords in our products & accessories.

Mounting the base unit on a wall

This phone can be mounted on any standard telephone wall plate.

- ① Route the AC adapter and the telephone cord through the hole of the wall mount bracket.

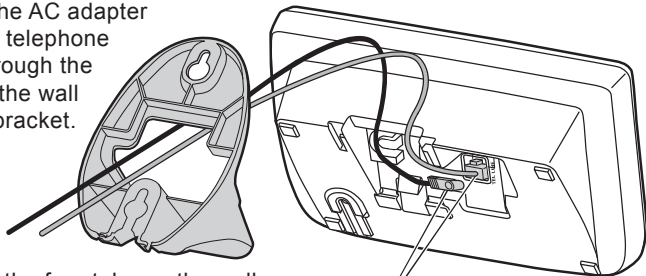

- ③ Line up the four tabs on the wall mount bracket (two at the top and two at the bottom) with the four notches on the bottom of the base. Slide the bracket into place.

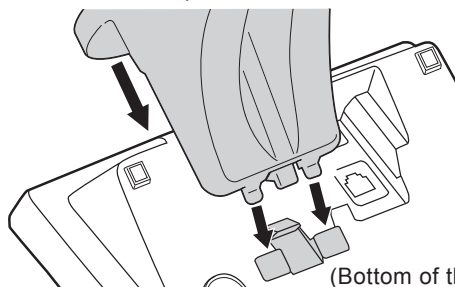

②

Connect the AC adapter and the telephone cords as shown on pages 3 and 4. Remember to route the AC adapter cord through the channel.

- ④ Hook the AC adapter cord into the smaller notch at the bottom of the bracket, and let the cord hang below the bracket.

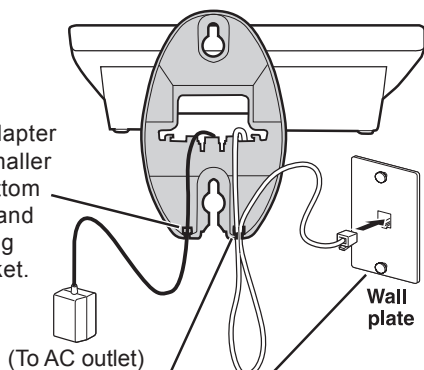

- ⑤ Plug the telephone cord into the wall jack. Hook both sides of the telephone cord into the larger notch OR tuck the excess cord into the open space in the bracket.

- ⑥ Place the mounting slots over the pins on the wall plate.

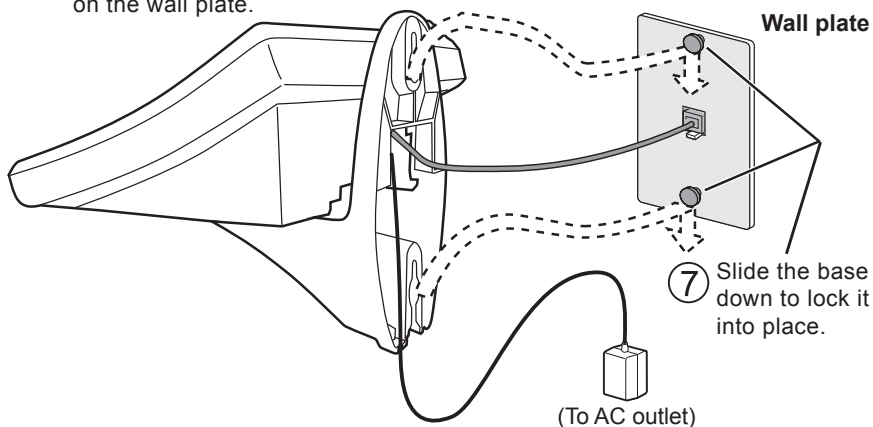

Removing the wall-mount bracket

At the bottom of the base, lift up on the release latch between the two bottom tabs and push the bracket up.

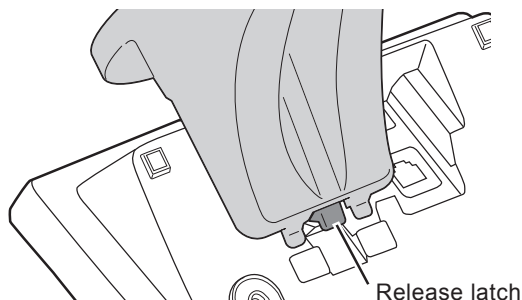

Note: Mounting the phone directly on the wall

- Be sure the wall is capable of supporting the weight of the phone, and use the proper type of anchoring device for the wall material.
- Insert two #10 screws (minimum length of 35mm, not supplied) into the wall, 100mm apart.
- Leave the screw heads 3mm away from the wall to allow room for mounting the phone.
- Align the mounting slots over the screws and slide the base down into place as shown above.

One Year Limited Warranty

UNIDEN XDECT 7055

IMPORTANT Evidence of the original purchase is required for warranty service.

Warrantor: Uniden Australia Pty Limited ABN 58 001 865 498
Uniden New Zealand Limited

Elements of Warranty: Uniden warrants to the original retail owner for the duration of this warranty its **XDECT 7055** (hereinafter referred to as the Product), to be free from defects in materials and craftsmanship with only the limitations or exclusions set out below.

Warranty Duration: This warranty to the original retail owner only is only valid in the original country of purchase and shall be of no further effect 1 year after the date of original retail sale. This warranty will be deemed invalid if the Product is: (A) Damaged or not maintained as reasonable and necessary, (B) Modified, altered or used as part of any conversion kits, subassemblies, or any configurations not sold by Uniden, (C) Improperly installed, (D) Repaired by someone other than an authorized Uniden Repair Agent for a defect or malfunction covered by this warranty, (E) Used in conjunction with any equipment or parts or as a part of a system not manufactured by Uniden. (F) Only available in the original country of sale.

Parts Covered: This warranty covers for one (1) year, the Product and included accessories.

Statement of Remedy: In the event that the Product does not conform to this warranty at any time while this warranty is in effect, the warrantor, at its discretion, will repair the defect or replace the Product and return it to you without charge for parts and service. This warranty does not provide for reimbursement or payment of incidental or consequential damages. This EXPRESS WARRANTY is in addition to and does not in any way affect your rights under the TRADE PRACTICES ACT 1974 (Cth) (Australia) or the CONSUMER GUARANTEES ACT (New Zealand).

Procedure for obtaining performance or warranty: in the event that the Product does not conform to this warranty, the Product should be shipped or delivered, freight prepaid, with evidence of original purchase (e.g. a copy of the sales docket) to the warrantor at:

UNIDEN AUSTRALIA PTY LTD
Service Division
345 Princes Highway,
Rockdale, NSW 2216
Fax (02) 9599 3278
www.uniden.com.au

UNIDEN NEW ZEALAND LTD
Service Division
150 Harris Road, East Tamaki,
Manukau 2013
Fax (09) 274 4253
www.uniden.co.nz

Uniden®

© 2009 Uniden Australia Pty Ltd/Uniden New Zealand Limited
Printed in Vietnam UNZZ01073BZ(0)